

GIGALAB EVO

mod.9265.063

INSTRUCTION MANUAL



EC CONFORMITY

Unit 9265.063 conform to EC directives **EMC - 2004/108/CE** the following harmonized standards are in use EN 60204-1, EN 61000-6-1, EN 61000-6-3.

SAFETY INSTRUCTIONS

ATTENTION : this instrument generates a 100V, 250V or 500V measuring voltage on the two external probes .

The current is limited to 1mA and cannot make any injury to the operator .

For operator's security, avoid to touch the electrodes directly.

Conforms to EN61010-1.

WARRANTY

This unit is guaranteed against all defects due to faulty materials and workmanship, within 12 months from the date of purchase.

A use not conforming to what specified might be dangerous to the safety of the operator and may damage the instrument.

In such circumstances the manufacturer is relieved of any liability and the warranty itself will decay.

REPAIR

Repairs have not been attempted by anyone other than authorized repair distributors.

Do not try to repair the unit by yourself.

ATTENTION: Dangerous voltage is present inside the instrument.

Protecting the environment

Separate collection. This product must not be disposed of with normal household waste.



Should you find one day that your product needs replacement, or if it is of no further use to you, do not dispose of it with household waste. Make this product available for separate collection.

Separate collection of used products and packaging allows materials to be recycled and used again.



Re-use of recycled materials helps prevent environmental pollution and reduces the demand for raw materials.

Local regulations may provide for separate collection of electrical products from the household, at municipal waste sites or by the retailer when you purchase a new product.

TECHNICAL FEATURES

The GIGALAB multi-voltage high resistance meter is a portable, accurate, and versatile instrument designed to measure resistance between two points, surface to ground, and surface resistivity as defined in IEC61340-5-1.

Graphic liquid crystal display 128x64 pixel, 68x51mm

Measuring range:	10V	from 1K Ω to 50G Ω
	100V	from 100K Ω to 1T Ω
	250V	from 500K Ω to 1T Ω
	500V	from 1M Ω to 1T Ω

Accuracy:	10V	$\pm 5\%$ $\pm 0.6\%$ per G Ω
	100V	$\pm 5\%$ $\pm 0.06\%$ per G Ω
	250V	$\pm 5\%$ $\pm 0.045\%$ per G Ω
	500V	$\pm 5\%$ $\pm 0.03\%$ per G Ω

the value of the measure is always displayed with 3 significant figures

Accuracy of measuring voltage: 100V $\pm 5\%$ ($R_{measure} > 300K\Omega$)
 250V $\pm 5\%$ ($R_{measure} > 2M\Omega$)
 500V $\pm 3\%$ ($R_{measure} > 5M\Omega$)

Humidity Range : 1 to 95%RH
 Resolution: 0.1%RH
 Accuracy: $\pm 2\%RH$ (@ 25°C, 10%RH~90%RH)
 $\pm 3\%RH$ (@25°C, 1%RH~10%, 90%RH~95%)

Temperature Range : -20°C to +60°C
 Resolution: 0.1°C
 Accuracy: $\pm 1^\circ C$

Batteries: 6 stylo, 1,5V IEC type LR6
 Battery life: About 1500 measurements (15 seconds max) at 500V

LOW BATTERY =  Blinking
 During Low Battery condition only the 10V measurements are allowed.
 Auto Shut-off after 5 minutes of inoperativity

Dimensions: 243x130x60mm
 Weight: 650g





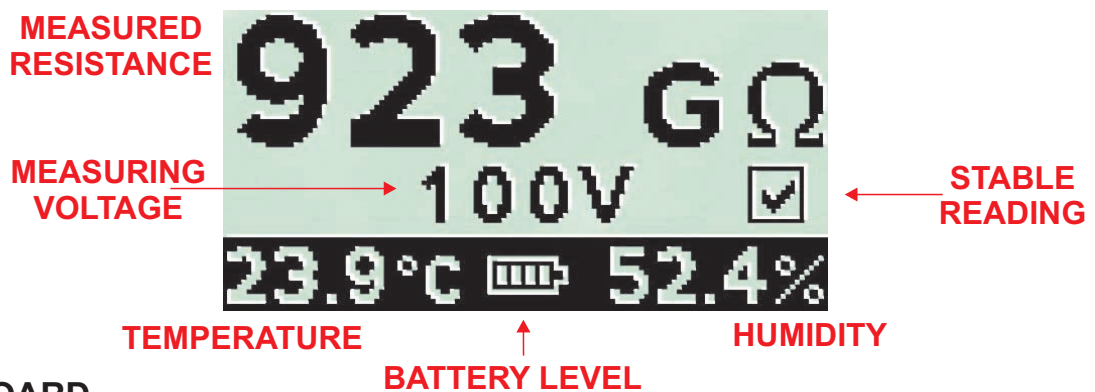

PROBES AND ACCESSORIES

9265.063	GIGALAB EVO meter with 2 shielded cables, batteries and case
9265.064	GIGALAB EVO complete kit including meter, 2 shielded probes 2 shielded cables, batteries and case
9265.045	Shielded probe 63mm / 2,3Kg, with two 4mm sockets and one BNC socket, Blue
9265.004B	Cylindrical probe, one 4mm socket, Black
9265.004R	Cylindrical probe, one 4mm socket, Red
9265.005	Concentric ring probe kit, one BNC socket, Black
9265.047	Flat shielded probe , with two 4mm sockets

DISPLAY



KEYBOARD

- 
 To enter the programming mode
- 
 To increase the measurement voltage
 To move to the previous menu while in programming mode
- 
 To display the measured resistance in natural or exponential format
 To advance the cursor while in programming mode
- 
 To decrease the measurement voltage
 To move to the next menu while in programming mode
- 
 To turn on / off the instrument and to exit programming mode
- 
 To turn on / off the instrument and to exit programming mode
- 
 To make the measurement
 To increase the value at the cursor location when you are in programming mode

FRONT PANEL

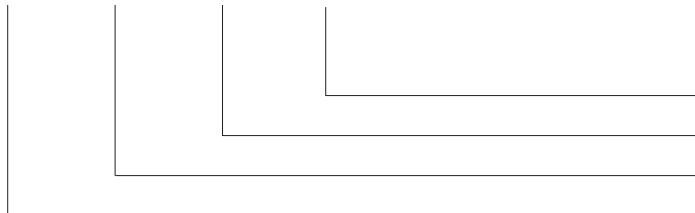
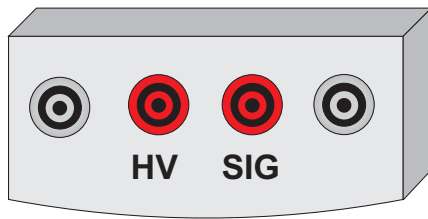

SIGNAL shield
SIGNAL input
HV input
HV shield

BATTERY REPLACEMENT

- Open the battery cover .
- Replace the battery (only alkaline type).



- Close the battery cover.

OPERATIVE INSTRUCTIONS

ON / OFF



In order to light-up GIGALAB EVO press  .
To shut-off GIGALAB EVO keep pressed the same key for 1 second

MEASURING VOLTAGE SETUP

Measuring voltage can be setted to 10, 100, 250, 500V
Then there is the mode 10 / 100V (auto) in which the instrument measures at:
10V when $R_x < 100K\Omega$
100V when $R_x > 100K\Omega$

Press and hold the button



for 1 second to increase the voltage measurement.

Press and hold the button



for 1 second to decrease the voltage measurement.

Choose the most appropriate voltage depending on the resistance value being measured and according to the IEC61340-5-1 regulation for the ESD.

DISPLAY FORMAT

The reading on the display can be set in natural or exponential format:

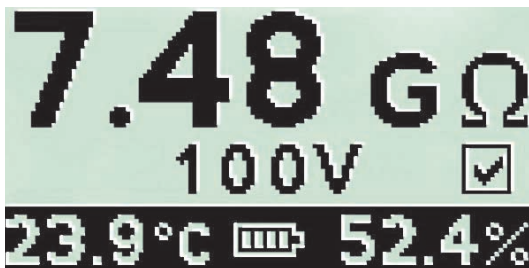

NATURAL FORMAT



EXPONENTIAL FORMAT

Press the button



for 1 second to switch from one format to another.

MEASUREMENT

Hold down the key



Wait until the measurement is stabilized (a check box at the right of the measured voltage indicates it).

Even if the measure stabilizes within seconds the regulation requires to wait at least 15 seconds for higher resistances.

Releasing the key

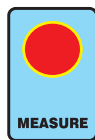

the value of the measurement made stay displayed and can be stored in memory (see next paragraph).

PROGRAMMING

Press and hold the button



for 1 second to enter the programming mode.

The menu of programming are 4:

- MEM
- ALARM
- ° C / ° F
- CONTRAST

Press the button  to move to the next menu.

Press the button  to move to the previous menu.

Press the button  to exit programming mode.

MEM

Menu of memory where you can store the data of 100 measures (from MEM 00 to 99 MEM)

The data stored for each measurement are:

- Resistance value
- Voltage used for the measurement
- Humidity detected during measurement
- Measured temperature during measurement

Press the button  to advance the cursor

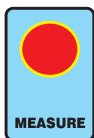
Press the button  to execute the command

Available commands are:

UP to switch to the next memory cell

DOWN to switch to the previous memory cell

STORE to store in the memory cell the measurement made

CLEAR to delete the data of the current memory cell or of all the memory cells (the choice between the two options is required immediately after the command)

NOTE: during the selection of the memory cell to be read or edited you can hold down the "MEASURE" pushbutton to move quickly to 10 cells at a time (10-20-30 etc)

ALARM

Alarm menu where you can set an audible alarm sounds when the resistance measurement is below or above a certain threshold.

Press the button  to advance the cursor

Press the button  to increase the digit of the cursor.

° C / ° F

Menu for setting the unit of temperature measurement:

- ° C degrees Celsius

- ° F degrees Fahrenheit

Press the button  to switch from one format to another.

DISPLAY

Menu for setting the contrast of the LCD display (0 to 9)

The default contrast is 5.

Press the button  to increase the value of contrast.

POINT TO POINT MEASUREMENT

Point to Point Measurement Rs with 2 Measuring Probes according to IEC 61340-5-1 for measurements of working surfaces, storage racks, transport boxes, etc

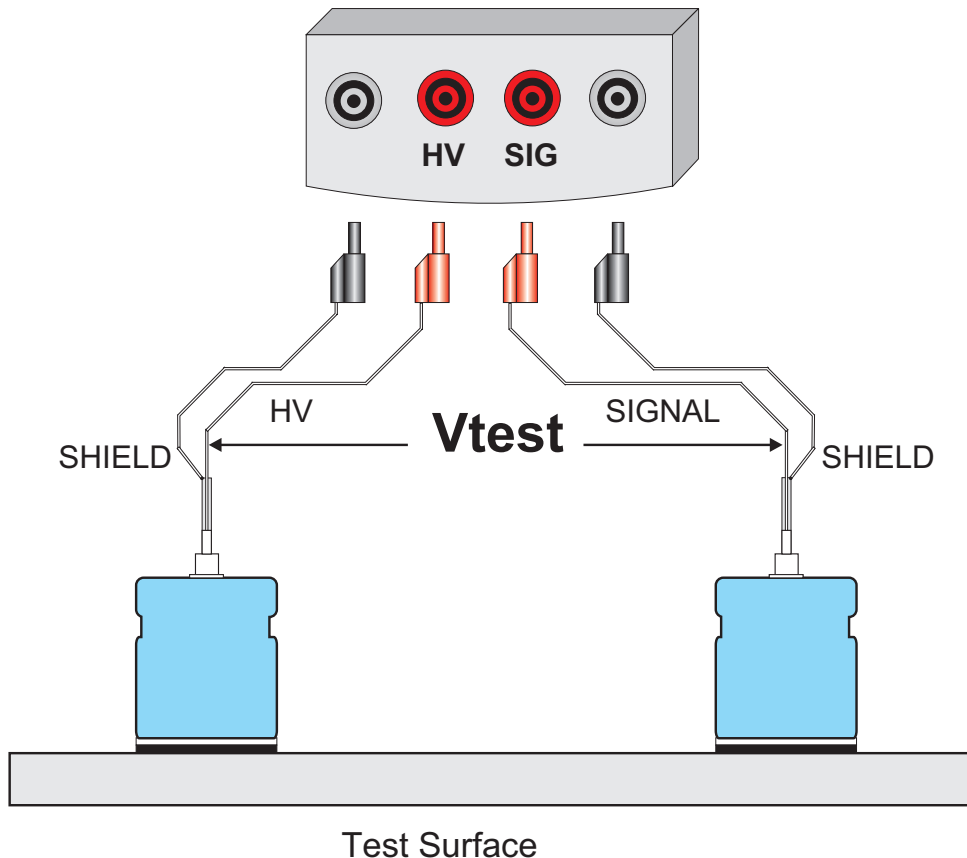

- Be sure that the surface under test is clean and free of grease or other chemicals than can create an isolant layer.
- In case of doubt clean the surface with a specific detergent, without alcohol or silicon, so that the non conductive layer will be removed.
- Place the 2 probes (9265.045 or 9265.004) on the test surface.
- Select the measuring voltage according the resistance value:

Vtest:	10V	for	$R_s \leq 10^5 \Omega$
	100V	for	$10^5 \Omega < R_s \leq 10^{12} \Omega$
- Press the central red pushbutton, and keep it pressed until the reading is complete.
- Continue to keep the button pressed and wait until the reading will be stable, settling time is higher for high resistance values, for resistances over 1G Ω you have to wait at least 10 seconds.

MEASURING WITH NON-SHIELDED PROBES

Insert the COAX/BANANA adaptor on the shielded cable as in the picture below:

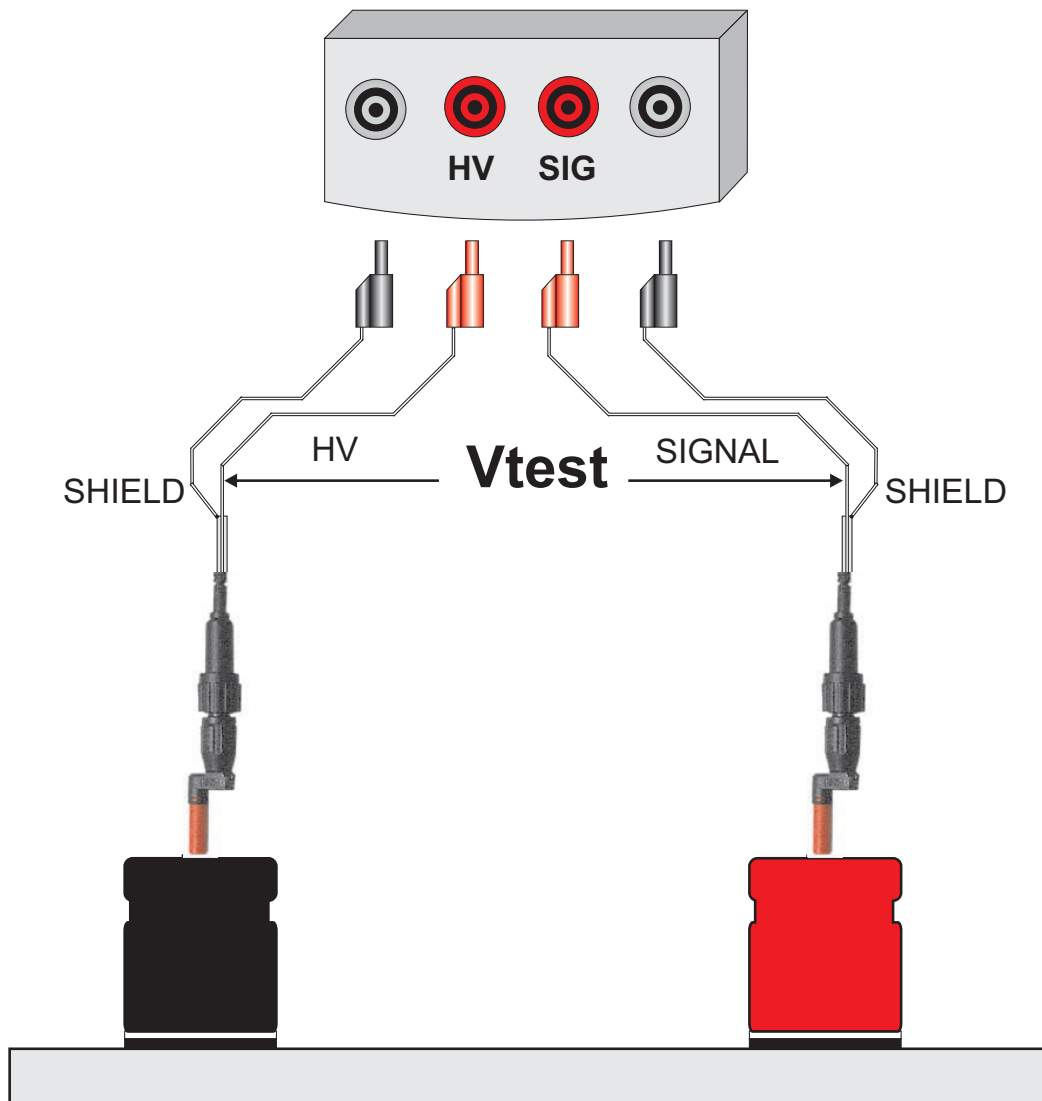

Test Surface

MEASURING RESISTANCE TO GROUND

Measuring Resistance to Ground according IEC61340-4-1 for measurements at flooring systems, table mats, chairs etc.

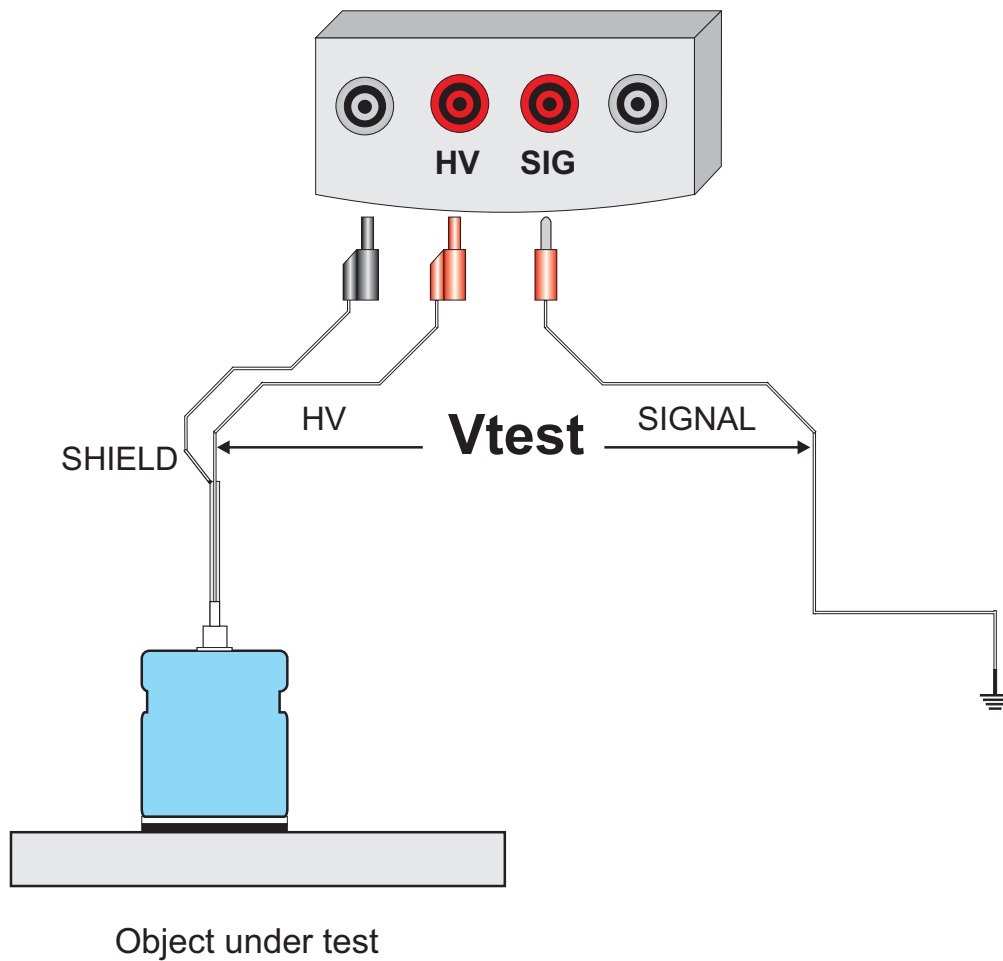

- Place the probe (9265.045 or 9265.004) on the test point.
- Select the measuring voltage according the resistance value:
V_{test}: 10V for R_G ≤ 10⁵Ω
 100V for 10⁵Ω < R_G ≤ 10¹²Ω
- Press the central red pushbutton, and keep it pressed until the reading is complete.
- Continue to keep the button pressed and wait until the reading will be stable, settling time is higher for high resistance values, for resistances over 1GΩ you have to wait at least 10 seconds.

MEASURING RESISTANCE THROUGH A PERSON TO GROUND

Measuring Resistance through a Person to Ground according IEC61340-4-5/NP for the measurement of a resistance through the combination of a person / shoes / flooring system .

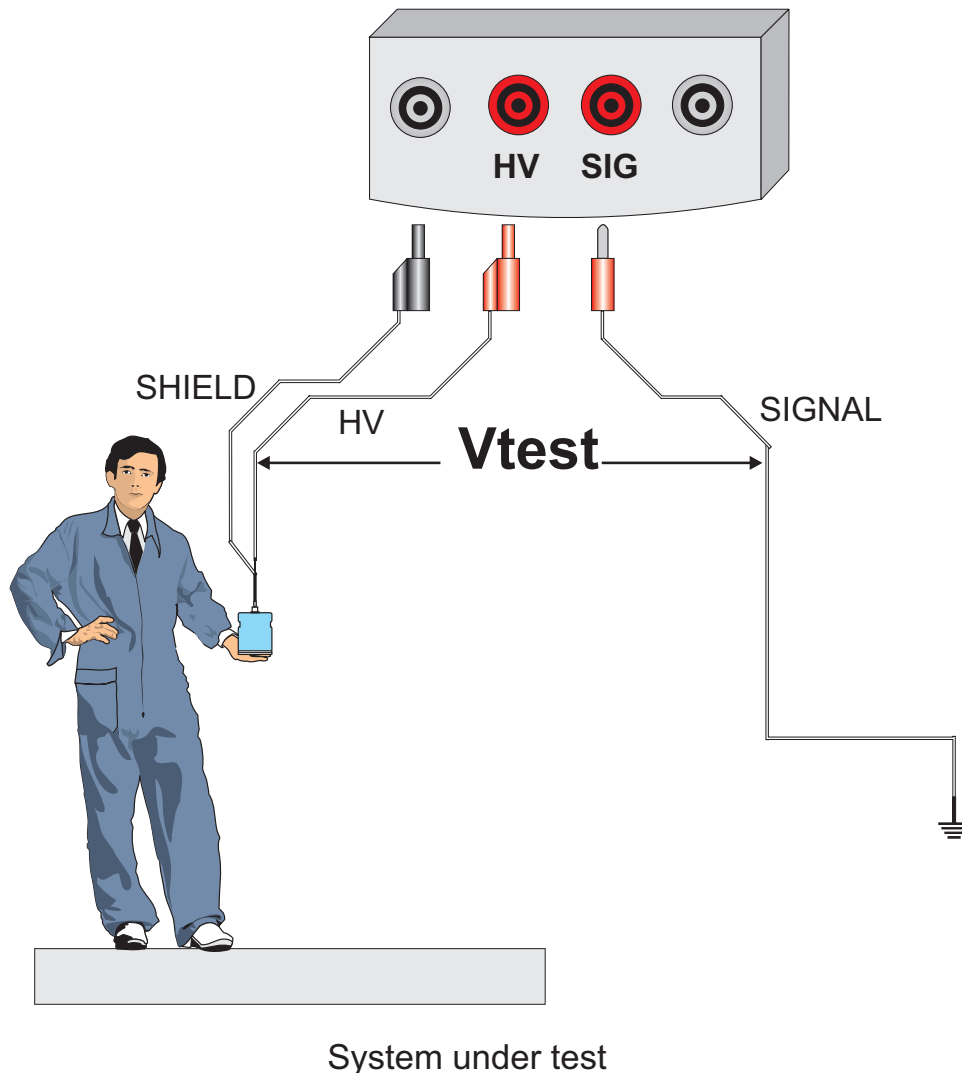

- Place the probe (9265.045 or 9265.004) on the operator's hand.
- Select the measuring voltage according the resistance value:
$$V_{test}: \quad 10V \quad \text{for} \quad R_G \leq 10^5\Omega$$
$$100V \quad \text{for} \quad 10^5\Omega < R_G \leq 10^{12}\Omega$$
- Press the central red pushbutton, and keep it pressed until the reading is complete.
- Continue to keep the button pressed and wait until the reading will be stable, settling time is higher for high resistance values, for resistances over $1G\Omega$ you have to wait at least 10 seconds.

MEASURING SURFACE RESISTANCE R_s

Measuring Surface Resistance R_s of Packaging Materials with a Ring Probe in compliance with IEC 61340- 5- 1 , for the measurement of conductive (dissipative) packaging materials.

- Be sure that the surface under test is clean and free of grease or other chemicals than can create an isolant layer.

- In case of doubt clean the surface with a specific detergent, without alcohol or silicon, so that the non conductive layer will be removed.
- Place the concentric ring probe (9265.005) on the surface under test.
- Select the measuring voltage according the resistance value:
 $V_{test}: \quad 10V \quad \text{for} \quad R_s \leq 10^5\Omega$
 $\quad \quad 100V \quad \text{for} \quad 10^5\Omega < R_s \leq 10^{12}\Omega$
- Press the central red pushbutton, and keep it pressed until the reading is complete.
- Continue to keep the button pressed and wait until the reading will be stable, settling time is higher for high resistance values, for resistances over 1G Ω you have to wait at least 10 seconds.

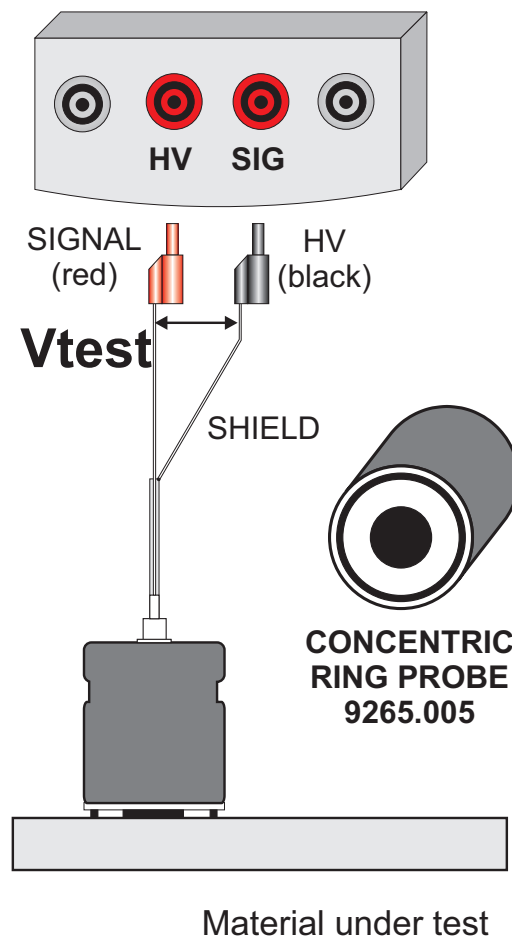

MEASURING VOLUME RESISTANCE R_v

Measuring Volume Resistance R_v with 1 cylindrical probe and a counter-electrode according IEC61340-5-1 for measuring the volume resistance of materials

- Place the counter-electrode (9265.047) under the material .
- Place the probe (9265.045 or 9265.004) over the material .
- Select the measuring voltage according the resistance value:
 $V_{test}: \quad 10V \quad \text{for} \quad R_v \leq 10^5\Omega$
 $\quad \quad 100V \quad \text{for} \quad 10^5\Omega < R_v \leq 10^{12}\Omega$
- Press the central red pushbutton, and keep it pressed until the reading is complete.

- Continue to keep the button pressed and wait until the reading will be stable, settling time is higher for high resistance values, for resistances over $1\text{G}\Omega$ you have to wait at least 10 seconds.

